

DATASHEET

ENGLISH

THE 4H - THE LOW-NOISE SOLUTION FOR SMALL ENGINE COOLING

The new 4H provides a good pressure capability and reduced noise level, especially when you are looking at the blade frequency sound contribution. The 4H also provides a cost-effective impeller utilising the H-range including the new flange version of 8 and 10 bladed hubs, and thus appropriate for flange mounted diesel engine applications.

We recommend use for this impeller type in for instance small diesel engine applications, condensers and evaporators in the refrigeration industry and ventilation application that requires moderate to high static pressures.

The impeller profile covers diameter areas from 284 mm to 702 mm and is with fixed pitch angles like the rest of the H range. It comes in the standard thermoplastic materials - a light grey PAG and a black PPG.

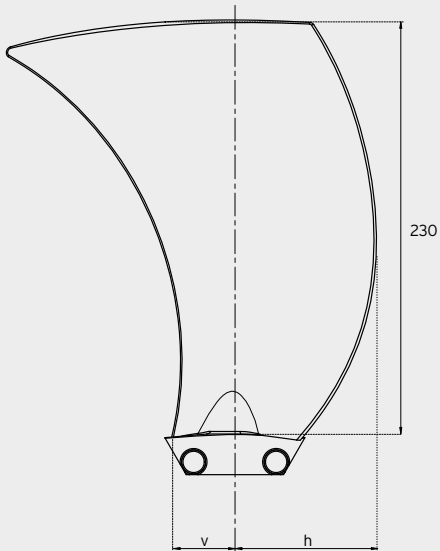

Design Features

Fixed pitch setting; 6 standard pitch angles ranging from 25° to 50°. Fan blades for both clockwise and counter-clockwise rotation. 6 hub sizes (3, 6, 8, 10, 12 & 14 blades all symmetrically arranged), each available in a range of bore/fixing configurations.

Materials

The hub parts are as standard manufactured in a pressure die cast silumin alloy (EN AC-AI Si12 Cu1 (Fe)). The 6 and 8-blade hubs are also available in a version manufactured in glass reinforced polypropylene (PPG), whereas the 3-blade hub is only available in a version manufactured in glass reinforced polyamide (PAG).

The fan blades are available in the following 2 materials to suit applications with different speeds and ambient temperatures.

PPG Glass reinforced polypropylene
Temperature range: -10°C to +80°C

PAG Glass reinforced polyamide
Temperature range: -40°C to +120°C

We reserve the right to change the materials of manufacture. The values for the mechanical properties are mean values and can be subject to variations due to the use of different suppliers.

Pitch	25°	30°	35°	40°	45°	50°
Leading edge $v \pm 2$	13	15	17	19	21	23
Trailing edge $h \pm 2$	37	42	47	52	57	61

All dimensions are in mm

Selection guide

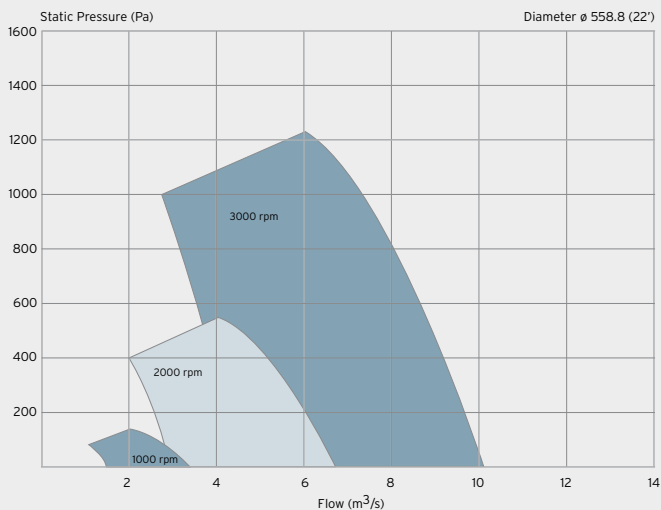

Selection guide

